

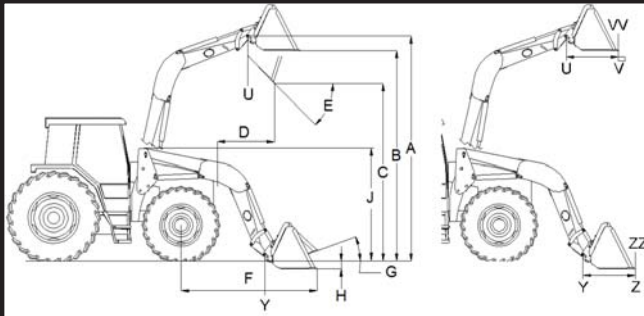

Hard Working & Rugged

JUST LIKE YOU



KMW 1760

The KMW 1760 Front End Loader is designed for 110 to 190 HP Tractors.

It features a 13'-8" Lift Height

SPECIFICATIONS OF LOADER

A.	Maximum Lift Height to Pivot Pin	13'8" (164")
B.	Maximum Lift Height under Level Bucket	12'-9.5" (153.5")
C.	Clearance with Bucket Fully Dumped	11'-5" (137")
D.	Reach at Maximum Lift Height	4'-2"
E.	Maximum Dump Angle	40°
F.	Reach with Bucket on Ground	8'-5" (101")
G.	Maximum Rollback Angle	32°
H.	Digging Depth	3"
J.	Overall Height in Carry Position	
U.	Lift Capacity to Maximum Height at Pivot Pin without Self Leveling	5600#
U.	Lift Capacity to Maximum Height at Pivot Pin with Hydraulic Self Leveling	5600#
V.	Lift Capacity to Maximum Height 31.5" Forward of Pivot Pin without Self Leveling	4100#
V.	Lift Capacity to Maximum Height 31.5" Forward of Pivot Pin with Hydraulic Self Leveling	3750#
W.	Lift Capacity to 59" Height at Pivot Pin	7550#
X.	Lift Capacity to 59" Height 31.5" Forward of Pivot Pin	5700#
Y.	Breakout Force at Ground Line at Pivot Pin	9300#
Z.	Breakout Force at Ground Line 31.5" Forward of Pivot Pin	6900#
VV.	Rollback Force at Maximum Height 31.5" Forward of Pivot Pin without Self Leveling	4050#
VV.	Rollback Force at Maximum Height 31.5" Forward of Pivot Pin with Hydraulic Self Leveling	3850#
XX.	Rollback Force at 59" Lift Height 31.5" Forward of Pivot Pin	6500#
ZZ.	Rollback Force at Ground Line 31.5" Forward of Pivot Pin	5800#
	PSI	2950 psi
	Lift Cylinder Diameter	3.50"
	Tilt Cylinder Diameter	2.75"



EURO STYLE BUCKET SPECIFICATIONS

		STRUCK CAPACITY	RATED CAPACITY
72"	Standard Capacity, General Purpose, Non-Grapple Ready Bucket	.65 cu. yd.	.84 cu. yd.
84"	Standard Capacity, General Purpose, Non-Grapple Ready Bucket	.75 cu. yd.	.97 cu. yd.
84"	Standard Capacity Bucket	.75 cu. yd.	.97 cu. yd.
96"	Standard Capacity Bucket	.87 cu. yd.	1.12 cu. yd.
102"	Standard Capacity Bucket	.92 cu. yd.	1.18 cu. yd.
84"	High Capacity Bucket	.84 cu. yd.	1.09 cu. yd.
96"	High Capacity Bucket	1.05 cu. yd.	1.33 cu. yd.
102"	High Capacity Bucket	1.11 cu. yd.	1.41 cu. yd.

FOR MORE INFORMATION

Specifications taken with 84" Standard Bucket.

Specifications based on ASAE standards S301.3 and furnished for general information only as they can vary with different tractor models.

Specifications are subject to change without notice and without liability therefore.

KMW Ltd. Sterling
535 West Garfield,
PO Box 327
Sterling, KS 67579-0327
USA

KMW Ltd. Great Bend
198 N. Hwy. 281
Great Bend, KS 67530
USA

Toll Free: (800) 445-7388
Sterling Local: (620) 278-3641
Sterling Fax: (620) 278-2388
Great Bend Fax: (620) 793-6737
Email: inquiry@kmwloaders.com



Hard Working & Rugged

JUST LIKE YOU

KMW loaders have a low profile, modern appearance, and are engineered for today's tractors.

Let us introduce you to our Front-End Loader Features

KMW 1760 Front-End Loader Features

- Mid-mount loader design
- Solenoid operated comfort drive
 - Improves operator comfort
 - Reduces strain on tractor/loader frame
 - Increases productivity
 - Extends unit's life
- Optional single lever hydraulic disconnect
- Optional loader valve with solenoid operated 3rd function
- High-strength materials used throughout all components
- Replaceable steel wear bushings located at critical pivot points
- Large radius side plates for modern appearance and improved strength
- Heavy duty attachment linkages increase dump and rollback angles
- Hydraulic oil supply hoses routed inside boom arm
 - Increases operator's visibility
 - Protects the hydraulic components
 - Enhances appearance
- Grease fittings conveniently located for easy lubrication
- Powder coat painted to match your tractor color
- Mounting brackets manufactured with large fillet welds
- Bracket supports welded inside and out
- Gr. 80 steel used in critical bracket components
- High quality heavy duty cylinders
- Reinforcement Doublers located in areas of high stress
- Optional 2-way hydraulic self-leveling
- Optional grill guards available



Pictures on this page are for general information only and may not pertain to this loader.

KMW 1760 Front-End Loader Attachments featuring Euro-style quick attach

- Grapples
 - Choose 4 or 6 tine – both have rugged 3/4" tines and dual cylinders
- Heavy duty buckets (Other options available, contact KMW)
 - Available in 3 widths: 84", 96" & 102"
 - 3" x 5" upper box cross tube
 - 3/4" x 6" cutting edge
 - 4 heavy duty wear bars
 - Reinforced side plates
 - Super strong loader brackets made with thick high-yield steel, high-stress areas welded inside and out
- Grapple ready
- Pallet Forks
- Bale Spears

We design loaders to fit AGCO, Buhler, Case International, John Deere, McCormick and New Holland tractors.